



User Manual

LucidControl DI16

16 Channel Digital Input USB Module

Table of Content

1	Introduction.....	3
2	Setup and Installation.....	3
2.1	Safety Information.....	3
2.2	USB Connection.....	4
2.3	Software	4
2.3.1	Microsoft Windows.....	4
2.3.2	Linux.....	4
2.3.3	LucidloCtrl Command Line Tool.....	4
2.3.4	First Steps	5
2.4	IO Configurations.....	6
2.4.1	Function Type 5-P Configuration.....	7
3	Module Operation.....	10
3.1	Real-time Considerations.....	10
3.1.1	Input Signal Value Inversion.....	10
3.1.2	Filter.....	10
3.1.3	Input Signal Value Inversion.....	10
3.2	Operation Modes.....	11
3.2.1	Reflect Mode.....	12
3.2.2	Edge Detection.....	13
3.2.2.1	Rising Edge Detection Mode	14
3.2.2.2	Falling Edge Detection Mode	14
3.2.3	Count Mode	15
3.2.3.1	Count Mode Options.....	16
3.3	Commands.....	18
3.3.1	Getlo.....	18
3.3.2	GetloGroup	20
3.4	Parameters.....	23
3.4.1	inDiValue.....	23
3.4.2	inDiMode.....	24
3.4.3	Bit Parameter inDiFlags	25
3.4.3.1	inDiInverted.....	25
3.4.3.2	inDiAddCounter.....	26
3.4.3.3	inDiResetCounterOnRead	26
3.4.4	inDiScanTime.....	27
3.4.5	inDiCountTime.....	27
4	Specification	29
5	Order Information	31
6	Document Revision.....	31

1 Introduction

This document describes the functionality of the LucidControl DI16 USB IO module with 16 digital input channels controllable by the Universal Serial Bus.

A basic description of the LucidControl product family can be found in the general *LucidControl User Manual*.

2 Setup and Installation

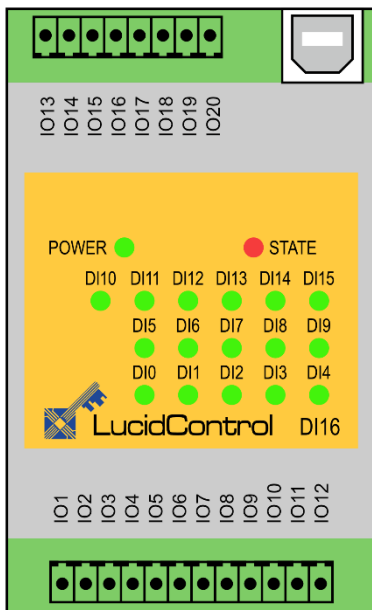

Fig. 1 shows the drawing of the DI16 digital input modules with 16 digital input channels.

The IO signals are connected to the lower (IO1 – IO12) and the upper (IO13 – IO20) IO terminals.

Fig. 1 LucidControl DI16 Module

2.1 Safety Information

LucidControl complies with regulations and industrial standards active in the EU. To keep the device functional, the following safety and maintenance information must be adhered.

The device must only be used for the intended purpose.

The device must not be used under the following conditions:

- It is obviously damaged
- An error was detected
- Outside humidity and temperature limits
- Unauthorized personnel



Never apply voltages higher than 30V to any IO terminal. This would damage the device.

2.2 USB Connection

LucidControl USB modules are connected to the computer by using a USB 2.0 cable which must not extend a length of 5 m. They are “bus powered” what means that the host computer supplies the module with power.

LucidControl DI16 module is rated with a maximum current of 250 mA.

2.3 Software

LucidControl modules are plug and play and a manual driver installation is not necessary.

First connection:

1. Ensure that no signal is applied to the IO terminals
2. Connect LucidControl via USB with the computer
3. Applies for Microsoft Windows before Windows 10 only: The system requests an installation file. This is not a driver but an information file (INF) only. It can be downloaded from our website <https://lucid-control.com/downloads>
4. LucidControl switches the green power LED on indicating that the module can be used.

2.3.1 Microsoft Windows

After the installation has finished, the Windows Device Manager lists a new serial port (COM) entry. The module can be accessed by using this port.

If more than one module is connected to a computer, the operating system ensures that the same serial port number is assigned to the module(s) after restart.

2.3.2 Linux

The module is immediately installed as `/dev/ttyACMn` device where `n` is a number referring to the index of the device.

Note:

If more than one module is connected to a computer, Linux does by default not ensure that a module is permanently linked to the same `/dev/ttyACMn` device.

2.3.3 LucidloCtrl Command Line Tool

The LucidloCtrl command line tool gives full access to all LucidControl modules. It is available for different architectures and can be downloaded from our website:

<https://www.lucid-control.com/downloads>

After downloading the program can be stored in a folder of choice.

Please see the general *LucidControl User Manual* for more information.

2.3.4 First Steps

After the module was successfully installed, the green power LED is switched on, signaling that the module is ready.

The following examples demonstrate the functionality of the module by using the LucidIoCtrl command line tool.

Windows Examples:

Reading the values of channels 0, 4, 7, 15 from a device connected to COM1

```
LucidIoCtrl -dCOM1 -tL -c0,4,7,15 -r  
-> CH0:00 CH4:00 CH7:00 CH15:00
```

Windows requires a different argument for comport numbers 10 and above.

```
LucidIoCtrl -d\\.\COM10 -c0,4,7,15 -r  
-> CH0:00 CH4:00 CH7:00 CH15:00
```

Linux Examples:

Reading the values of channels 0, 4, 7, 15 from a device connected to /dev/ttyACM0.

```
LucidIoCtrl -d/dev/ttyACM0 -c0,4,7,15 -r  
-> CH0:00 CH4:00 CH7:00 CH15:00
```

2.4 IO Configurations

The DI16 module is available in different configurations, which are explained in this section.

Function Class	Value	Channels
DI16	0x0030	16

Tab. 1 Digital Input Function Class

Function Class Type	Value	Threshold Level
5	0x1000	5V
5-P (→ 2.4.1)	0x1010	5V
10	0x1001	10V
24	0x1005	24V

Tab. 2 Digital Input Function Class Types

Tab. 1 and Tab. 2 list the Function Class and their types.

The digital inputs are available with different threshold levels:

Function Class Type	V_{LowMax}	$V_{HighMin}$	$V_{HighMax}$
5	2.5 V	3.5 V	7.5V
10	6.0 V	8.5V	15V
24	16.0 V	21.0 V	30V

Tab. 3 Digital Input Threshold Levels

Tab. 3 shows the characteristic voltages for the different threshold levels.

Voltages below V_{LowMax} result in a LOW value, voltage higher than $V_{HighMin}$ in a HIGH value. Because of the input hysteresis, voltages between V_{LowMax} and $V_{HighMin}$ do not change the logic value.

In order to prevent excessive stress on the digital inputs, the maximum applied voltage must not exceed $V_{HighMax}$.

A high input state is indicated by a green status LED.

Example

When interfacing a 24 V signal, the applied voltage of a HIGH state must be higher than 21.0 V. The voltage of a low state needs to be lower than 16.0 V. For the voltages between, the last detected stable value remains.

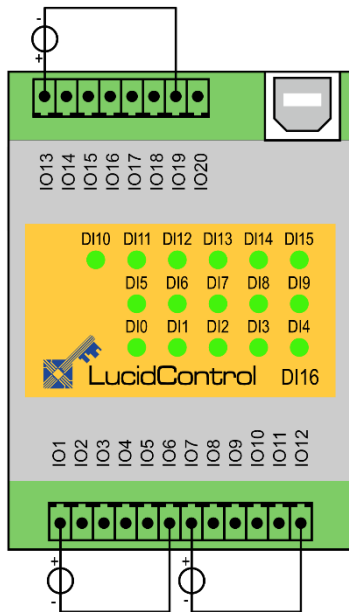

Fig. 2 DI16 IO Connection

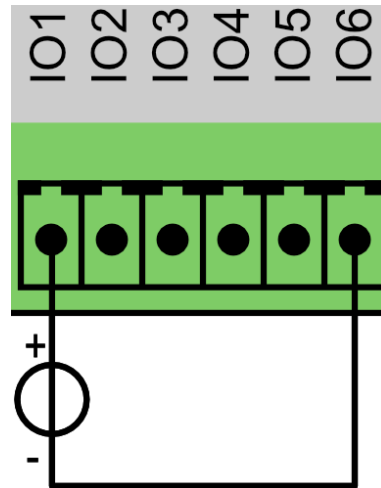

Fig. 3 DI16 Signal

Fig. 2 shows the connection of the DI16 with inputs connected to 3 input channels.

Fig. 3 shows in detail the voltage source connected to IO terminals IO1 and IO6.

2.4.1 Function Type 5-P Configuration

The Function Type 5-P is a special configuration of the DI16 which provides a not isolated voltage of approx. 5V (U_P) at IO terminal 20.

The IO terminals 6, 12, and 19 are connected to system ground of the host computer and the ground lines are not isolated.

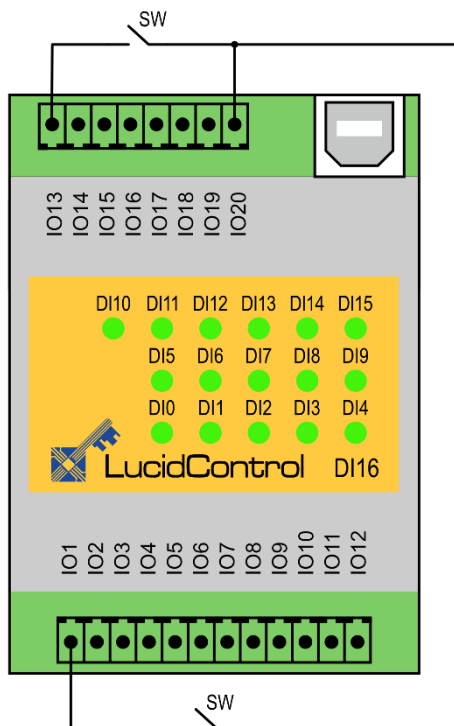

Fig. 4 IO20 Voltage Source

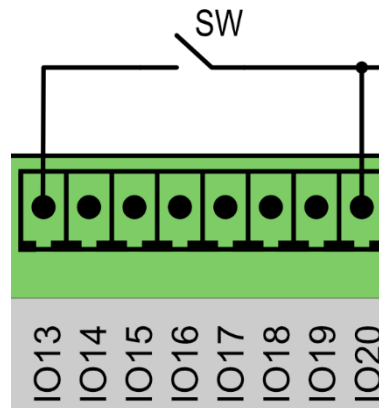

Fig. 5 Switch Detail

Fig. 4 and Fig. 5 show how a digital input signal can be realized without the need of an external power supply.

The voltage U_P is applied to the two switches which are connected to DI0 and DI10 of the DI16-5-P module. If the switches are closed, the inputs are set to high state.

The current supplied by IO20 is sufficient to drive all input channels.



Max. I_P must be considered. The voltage should be used for driving the input channels, only.

Tab. 4 lists the IO terminals of the DI16 module and their IO channel numbers.

The GND terminals are grouped for the highlighted input channels.

IO terminal 6 for example is the common ground line for the IO signals DI0 + to DI4 +.

IO Terminal	Signal	IO Channel Number
1	DI0 +	0
2	DI1 +	1
3	DI2 +	2
4	DI3 +	3
5	DI4 +	4
6	GND DI0-DI4	
7	DI5 +	5
8	DI6 +	6
9	DI7 +	7
10	DI8 +	8
11	DI9 +	9
12	GND DI5-DI9	
13	DI10 +	10
14	DI11 +	11
15	DI12 +	12
16	DI13 +	13
17	DI14 +	14
18	DI15 +	15
19	GND DI10-DI15	
20	U _P	5V-P only

Tab. 4 DI16 IO Terminal Connector

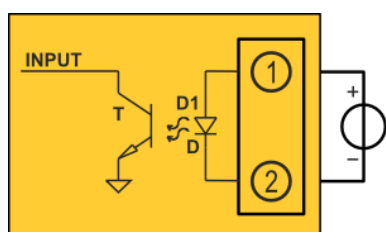

Fig. 6 Digital Input Principle

Fig. 6 illustrates the principle of the digital input channels. The input signal applied to the IO terminals 1 and 2 (DI0) powers the LED of the opto-coupler, which insulates the input signal and the acquisition hardware.

3 Module Operation

3.1 Real-time Considerations

Operating systems for personal computers are not made for deterministic real-time operation. Because of multitasking it cannot be ensured that a task will continue to run within a specified interval.

USB is also no real-time bus and limits the timing.

Assuming that short pulses (e.g. shorter than 10 ms) should be detected, the computer has to read the input value at least 100 times per second what is not realistic. It is possible that a pulse is located between two readings and the pulse would be missed.

Edge detection and count modes improve the real-time characteristics.

3.1.1 Input Signal Value Inversion

Digital input channels have an input signal value and a logical input value. The input signal value is represented by the voltage applied to the input channel. The logical value is evaluated by the input processing.

In case of inversion is disabled, the input signal values and logical values are identical.

In case of input inversion is enabled by configuration parameter *inDiInverted* set to "on" the logical value is the inverted input signal value. This means that a voltage higher than $V_{HighMin}$ results in a HIGH input signal value but a LOW logical input value.

All input modes support input signal value inversion.

3.1.2 Filter

The digital input signal is filtered and only stable high or low signals are evaluated. This function allows the input channel to debounce the signal.

Signals are only considered valid if they are stable during the time T_{Scan} (→ 3.4.4 → Fig. 8).

3.1.3 Input Signal Value Inversion

Digital input channels consist of input signal value and a logical input value. The input signal value is represented by the voltage applied to the input channel. The logical value is evaluated by the input processing.

In case of inversion is disabled, the input signal values and logical values are identical.

In case of input inversion is enabled by configuration parameter *inDiInverted* ($\rightarrow 0$) set to "on" the logical value is the inverted input signal value. This means that a voltage higher than V_{HighMin} results in a HIGH input signal value but a LOW logical input value (\rightarrow Fig. 9).

All input modes support the inversion of input value.

3.2 Operation Modes

This section explains the operation modes of the input channels and gives examples how to configure and to use them.

Digital input channels can operate in one of the modes:

- Reflect Mode
- Rising Edge Mode
- Falling Edge Mode
- Count Mode

In all modes the input values are captured and evaluated after a stable signal has been detected.

3.2.1 Reflect Mode

The reflect mode acquires the logical input value.

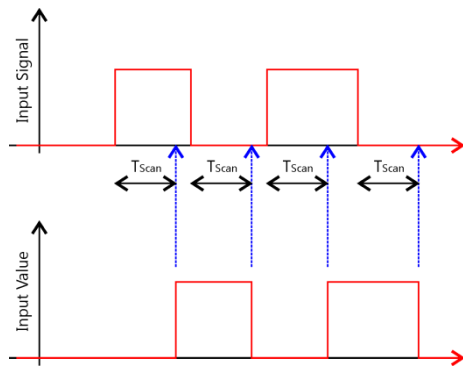
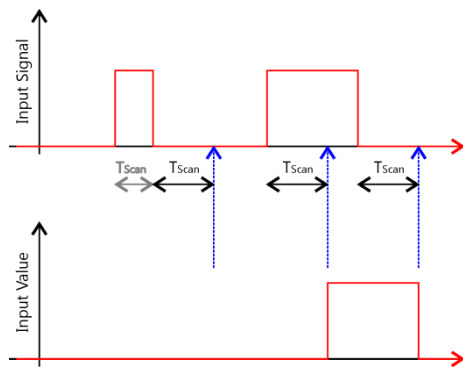

Fig. 7 illustrates the processing of the digital input channels in reflect mode.

After the rising edge of the input signal was detected and it remained stable for the interval T_{Scan} the input value is updated.

Fig. 7 Digital Input Channel Processing in Reflect Mode



In the case that a pulse of the input signal is shorter than T_{Scan} , it is ignored and the input value does not change. Fig. 8 shows this at the first pulse. The rising edge of the input signal starts the scan timer and the falling edge stops it (indicated by the gray T_{Scan} interval).

The second pulse is longer than T_{Scan} and considered valid. The input value is updated.

Fig. 8 Reflect Mode Pulse Width

Filtering digital signals can be used in order to suppress instable signals (debouncing). It makes the detection of digital input signals more reliable.

The scan interval T_{Scan} is configured by the parameter *inDiScanTime* (→ 3.4.4).

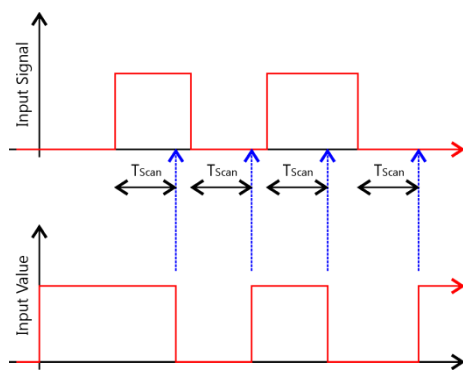

Fig. 9 illustrates the digital input signal and the inverted input value with parameter *inDiInverted* set to "on".

Fig. 9 Inverted Reflect Mode

LucidIoCtrl Command Line Tool Example

Set digital input channel 0 to Reflect Mode

```
LucidIoCtrl -dCOM4 -c0 -sinDiMode=reflect
```

3.2.2 Edge Detection

Digital input channels can operate in edge detection modes. In rising edge mode, the channel is sensitive for low-to-high transitions, in falling edge mode it recognizes high-to-low transitions.

Edge detection modes improve the real-time processing of input signal transitions without the host computer being involved.

The length of the shortest valid pulse is configured by the scan interval time T_{Scan} .

Example

The input should be able to detect an input signal pulse of 100 μ s length.

In theory it would be sufficient to read the digital input in reflect mode every 50 μ s (with safety time) in order to detect the transition by the computer. But probably the operating system of the computer would violate the timing restrictions and pulses are lost.

In edge detection mode this can be solved by setting $T_{Scan} = 90 \mu$ s (including safety).

LucidIoCtrl Command Line Tool Example

Configure input channel 0 for rising edge detection mode

```
LucidIoCtrl -dCOM4 -c0 -sinDiMode=risingEdge
```

Set T_{Scan} to 90 μ s

```
LucidIoCtrl -dCOM4 -c0 -sinDiScanTime=90000
```

Read input channel 0

```
LucidIoCtrl -dCOM4 -c0 -tL -r  
-> CH0:01
```

3.2.2.1 Rising Edge Detection Mode

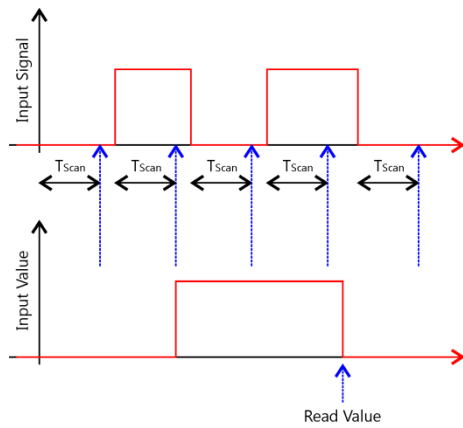
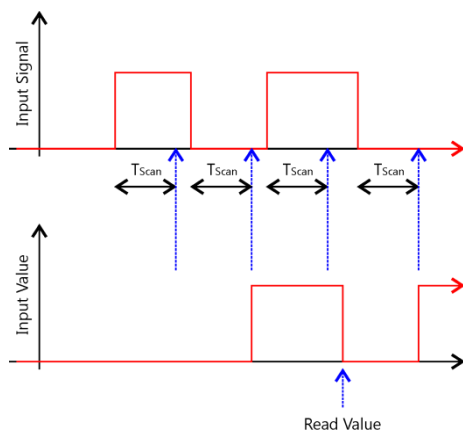

Fig. 10 shows a digital input signal and the corresponding input value in rising edge detection mode. After the HIGH input signal was detected as being valid, the input value remains pending until it was read by the host computer.

The rising edge detection mode allows detecting low-to-high transitions of the input signal without the host computer being involved.

Fig. 10 Rising Edge Detection Mode

3.2.2.2 Falling Edge Detection Mode



The falling edge detection mode (Fig. 11) operates similar to the rising edge detection mode (→ 3.2.2.1) but triggers at high-to-low transition of the input signal.

In falling edge detection mode, a high-to-low transition of the input signal sets the input value to "1".

Fig. 11 Falling Edge Detection Mode

3.2.3 Count Mode

The count mode accumulates valid pulses of the input signal within a count interval specified by T_{Count} .

The counter is 16 bit wide. When 65535 is reached it rolls over to 0 with the next increment.

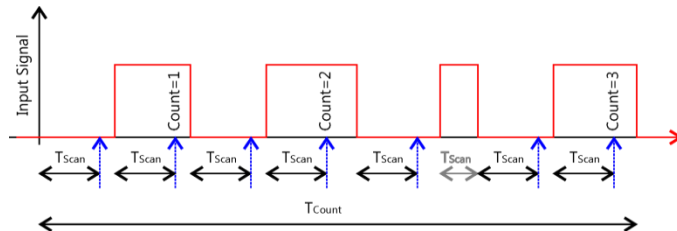

Fig. 12 Count Mode

Fig. 12 illustrates a typical periodical input signal. In count mode all valid pulses are accumulated until the count interval T_{Count} finishes.

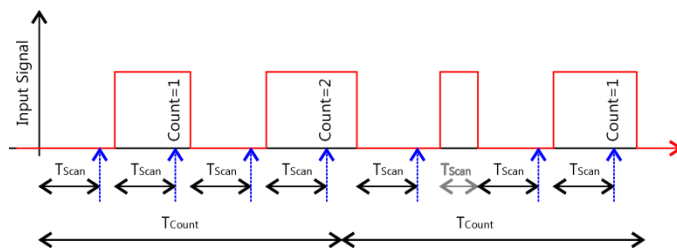

Fig. 13 Count Mode Interval

Fig. 13 shows the same input signal, but with a shorter count interval.

After count interval T_{Count} has passed, the count value is accessible and a new measurement cycle starts.

The input signal is considered as valid after it was stable for at least the scan time T_{Scan} . Only valid pulses are accumulated (see the gray interrupted pulse).

T_{Scan} time starts when the rising edge of the input signal was detected. In the case that the parameter *inDiInverted* is set to "on", T_{Scan} time starts when the falling edge of the input signal is detected.

Reading the input value in count mode returns the count value of the last finished count interval cycle.

LucidIoCtrl Command Line Tool Example

Configure input channel 0 for Count Mode

```
LucidIoCtrl -dCOM4 -c0 -sinDiMode=count
```

Set Scan Time T_{Scan} to 1ms

```
LucidIoCtrl -dCOM4 -c0 -sinDiScanTime=1000
```

Set Count Time T_{Count} to 1s

```
LucidIoCtrl -dCOM4 -c0 -sinDiCountTime=1000000
```

Read count value (number of pulses)

```
LucidIoCtrl -dCOM4 -c0 -tN -r
-> CH0:0x0064 (100)
```

In this example 100 pulses of at least 1 millisecond length have been acquired within a count interval of 1 second.

Since the input value is updated after count interval has passed it takes 1 second to update the value. Decreasing the count interval results in a faster update of the input value.

In Count Mode the value type N is supported. The count value is returned in hexadecimal and decimal format.

3.2.3.1 Count Mode Options

The functionality of the count mode can be controlled by the parameters *inDiAddCounts* and *inDiResetCountsOnRead*.

The number counted pulses becomes valid after count interval T_{Count} has passed:

- In the case that *inDiAddCounter* is set to "off", the current counter value is overwritten by the new counter value and previous counter value might be lost.
- In the case that *inDiAddCounter* is set to "on", the new counter value is added to the current counter value.

When the count number is read by the host:

- If *inDiResetCounterOnRead* is set to "off", reading the counter value does not affect the counter value.
- If *inDiResetCounterOnRead* is set to "on", the counter value is reset after reading it.

The parameter *inDiResetCounterOnRead* has only an effect when *inDiAddCounter* set to "on".

In order to avoid counter overflows parameter *inDiAddCounter* "on" should be combined with *inDiResetCounterOnRead* "on" parameter.

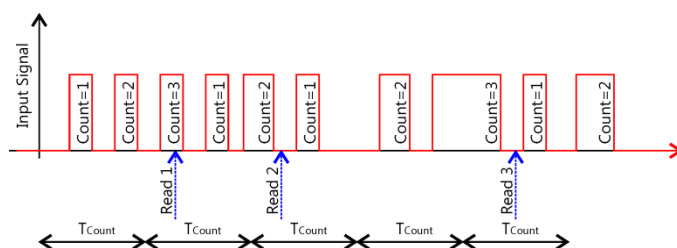

Fig. 14 Count Value Add Mode

Fig. 14 shows a non-periodic input signal with 10 pulses in total. The counter value is read at 3 times. In the following it is explained how the options affect the count value.

The value "Count" in the diagram refers to the internal counter which is accumulated during count interval T_{Count} .

Mode	Value Read 1	Value Read 2	Value Read 3
<i>inDiAddCounter</i> = "on" <i>inDiResetCounterOnRead</i> = "on"	2	3	3
<i>inDiAddCounter</i> = "on" <i>inDiResetCounterOnRead</i> = "off"	2	5	8
<i>inDiAddCounter</i> = "off" <i>inDiResetCounterOnRead</i> = "off" (Default)	2	3	2

Tab. 5 Count Mode Options Value Read Results

Tab. 5 lists the count values at the 3 reading positions for the *inDiAddCounter* and *inDiResetCounterOnRead* options.

The options *inDiAddCounter* and *inDiResetCounterOnRead* are set to "on" which is the most useful combination. (→ Tab. 5, first row)

On Read 1 the returned counter value is 2 since the internal counter value when T_{Count} ended was 2. The counter value is reset on reading and 1 pulse is carried over to the next T_{Count} interval.

On Read 2 the returned counter value is 3 because of the internal counter value 2 plus the carried over counter 1 from the last count interval. The counter value is reset on read.

At the reading 3 the read value is 3. The counter value is reset on read.

Count mode with *inDiAddCounter* = "on"

In the case that *inDiAddCounter* is "on" and *inDiResetCounterOnRead* is "off" the pulses are accumulated but the counter is not reset on reading the value. This causes the counter value will be updated when count interval has finished and the current counter is added to the last counter value. This may result in an overflow when the counter value rolls over its maximum value of 65535.

3.3 Commands

LucidControl IO Modules can be accessed by the Frame Protocol, which is documented in the general *LucidControl User Manual*.

This section describes in detail the commands which are supported by the DI16 modules.

3.3.1 Getlo

This command reads the logic value of an input.

Mode	Value
Reflect	Logic input value 0 or 1
Edge Detection	Pending edge event detected value 0 or 1
Count	Counter value 0 to 65535

Tab. 6 Value of Digital Input Channel

Tab. 6 lists the digital input channel modes and how the IO value is interpreted.

Command	Getlo	Access	Read
Opcode	0x46		
LucidIoCtrl Command Line Tool			
Call (-tL)	LucidIoCtrl -d[COMx] -c[Channel] -tL -r		
Return	CHn:L		
	n	Input Channel	
	L	Input Digital Value	
Call (-tN)	LucidIoCtrl -d[COMx] -c[Channel] -tN -r		
Return	CHn:V		
	n	Input Channel	
	V	Input Count Value	

Tab. 7 Getlo Command

LucidIoCtrl Command Line Tool Example

Read input channel 0. The module is operating in Reflect or Edge Detection Mode

```
LucidIoCtrl -dCOM4 -c0 -tL -r
-> CH0:01
```

Read input channel 0 operating in Count Mode

```
LucidIoCtrl -dCOM4 -c0 -tN -r
-> CH0:0x0064 (100)
```

Request Frame

OPC	P1	P2	LEN
0x46	Channel	Value Type	0

Tab. 8 Getlo Request Frame

Value	Description									
Channel	Number of input channel (Range: 0 - 15)									
Value Type	Supported Value Types <table border="1"> <thead> <tr> <th>Value Type</th> <th>Value Range</th> <th>Size</th> </tr> </thead> <tbody> <tr> <td>Digital Logic Value (0x00)</td> <td>0 / 1</td> <td>1 Byte</td> </tr> <tr> <td>Digital Counter Value (0x0A)</td> <td>0 - 65,535</td> <td>2 Bytes</td> </tr> </tbody> </table>	Value Type	Value Range	Size	Digital Logic Value (0x00)	0 / 1	1 Byte	Digital Counter Value (0x0A)	0 - 65,535	2 Bytes
Value Type	Value Range	Size								
Digital Logic Value (0x00)	0 / 1	1 Byte								
Digital Counter Value (0x0A)	0 - 65,535	2 Bytes								

Tab. 9 Getlo Request

Response Frame:

Status	LEN	Data Field
Status	Size	Value

Tab. 10 Getlo Response Frame

Returns Execution Status Code, documented in the general *LucidControl User Manual*.

In case of successful execution, the command returns the value of the specified channel number.

3.3.2 GetloGroup

This command reads the logic input values of a group of input of the same Value Type.

Command	GetloGroup	Access	Read				
Opcode	0x48						
LucidIoCtrl Command Line Tool							
Call (-tL)	LucidIoCtrl -d[COMx] -c[Channels] -tL -r <u>Channels:</u> Comma separated list of channels e.g. -c0,1,3						
Return	List of values sorted from lower to higher channels CHn:LL <table border="1" style="width: 100%;"> <tr> <td style="width: 15%;">n</td> <td>Input Channel</td> </tr> <tr> <td>LL</td> <td>Input Digital Value</td> </tr> </table>			n	Input Channel	LL	Input Digital Value
n	Input Channel						
LL	Input Digital Value						
Call (-tN)	LucidIoCtrl -d[COMx] -c[Channels] -tN -r <u>Channels:</u> Comma separated list of channels e.g. -c0,1,3						
Return	List of values sorted from lower to higher channels CHn:vv <table border="1" style="width: 100%;"> <tr> <td style="width: 15%;">n</td> <td>Input Channel</td> </tr> <tr> <td>vv</td> <td>Input Counter Value</td> </tr> </table>			n	Input Channel	vv	Input Counter Value
n	Input Channel						
vv	Input Counter Value						

Tab. 11 GetloGroup Command

LucidIoCtrl Command Line Tool Example

Read input values of input channel 0, 7 and 15:

```

LucidIoCtrl -dCOM4 -c0,7,15 -tL -r
-> CH0:00 CH7:01 CH15:01
    
```

Request Frame

OPC	P1	P2	LEN
0x48	Channel Mask	Value Type	0

Tab. 12 GetloGroup Request Frame

Value	Description			
Channel Mask	Channel Mask Specifies the input channels to access			
	Channel	Bit Position P1		
	P1	P1A	P1B	
	0	0		
	1	1		
	2	2		
	3	3		
	4	4		
	5	5		
	6	6		
	7	7	0	
	8	7	1	
	9	7	2	
	10	7	3	
	11	7	4	
	12	7	5	
13	7	6		
14	7	7	0	
15	7	7	1	
	Values are bitwise or combined Size of P1 is 1 - 3 bytes. If Bit 7 of P1 is set, a subsequent P1 byte is present.			
	<p><u>Examples:</u></p> <p>Accessing channel numbers:</p> <p>0 and 3 Value P1 = 0x01 OR 0x08 = 0x09</p> <p>1 and 7 Value P1 = 0x02 OR 0x80 = 0x82</p> <p> Value P1A = 0x01</p> <p>1 and 15 Value P1 = 0x02 OR 0x80 = 0x82</p> <p> Value P1A = 0x80 (no channel but P1B)</p> <p> Value P1B = 0x02 (channel 15)</p>			
Value Type	Supported Value Types			
	Value Type	Value Range	Response Len	
	Digital Logic Value (0x00)	0 / 1	1 Byte	
Digital Counter Value (0x0A)	0 - 65,535	2 Bytes		

Tab. 13 GetloGroup Command

Response Frame:

Status	LEN	Data Field
Status	Length	Value

Tab. 14 GetloGroup Response Frame

Returns Execution Status Code, documented in the general *LucidControl User Manual*.

In case of successful execution, the command returns the read values of the channels specified in the Channel Mask in channel number ascending order.

Example of GetloGroup Request:

Request frame reads input channels 0, 7 and 15

OPC	P1	P1A		P2	Length
0x48	0x81	0x81	0x02	0x00	0x00

Tab. 15 GetloGroup Request Example

Response Frame:

For input 0 = "0", input 7 = "1" and input 15 = "1"

Values in Data Field are in ascending order

Header Field		Data Field		
Status	LEN	CH0	CH7	CH15
0x00	0x03	0x00	0x01	0x01

Tab. 16 GetloGroup Response Example

3.4 Parameters

LucidControl modules are configured by a set of System Configuration Parameters and IO Configuration Parameters.

The parameters are accessible by the SetParam and GetParam commands, which are described in the *LucidControl User Manual*.

Parameter values can be made persistent in the non-volatile memory of the microcontroller e.g., by adding the -p argument to LucidIoCtrl or by setting the persistent parameter in the API function to true. Values of persistent parameters are restored when LucidControl is powered on.

The number of write cycles to the non-volatile memory is limited. Write operations wear out the non-volatile memory and periodical updates of persistent parameter values should be avoided in order not to destroy the device over time.

3.4.1 inDiValue

This IO Configuration Parameter reflects the value of the input channel.

In Reflect Mode and Edge Detection Mode the parameter contains the input value as it can also be read by GetIo or GetIoGroup command.

If the input is configured in Count Mode this parameter is "0".

Parameter	<i>inDiValue</i>	Access	Read
Address	0x1000		
Values	Input Value		
Default Value	0x00	Parameter Type	1 Byte unsigned
LucidIoCtrl Command Line Tool			
Parameter Name	<i>inDiValue</i>	Parameter Values	0 / 1
Call (Get)	LucidIoCtrl -d[COMx] -c[Channel] -ginDiValue		

Tab. 17 IO Configuration Parameter *inDiValue*

LucidIoCtrl Command Line Tool Example

Read value of input channel 0:

```

    LucidIoCtrl -dCOM4 -c0 -ginDiValue
->    inDiValue=0

```

3.4.2 inDiMode

This IO Configuration parameter configures the operation mode of the input.

Parameter	<i>inDiMode</i>	Access	Read / Write
Address	0x1100		
Values	Input Mode		
	Byte	Mode	
	0x00	inactive	
	0x01	reflect	
	0x10	risingEdge	
	0x11	fallingEdge	
	0x20	count	
Default Value	0x00	Parameter Type	1 Byte unsigned
LucidIoCtrl Command Line Tool			
Parameter Name	<i>inDiMode</i>	Parameter Values	Mode
Call (Set)	LucidIoCtrl -d[COMx] -c[Channel] -sinDiMode=[Mode] {-p} {--default}		
Call (Get)	LucidIoCtrl -d[COMx] -c[Channel] -ginDiMode		

Tab. 18 IO Configuration Parameter inDiMode

LucidIoCtrl Command Line Tool Example

Set operation mode of input channel 0 to Count Mode and make the setting persistent.

```
LucidIoCtrl -dCOM4 -c0 -sinDiMode=count -p
```

Read the operation mode of input channel 0

```
LucidIoCtrl -dCOM4 -c0 -ginDiMode
-> inDiMode=count
```

3.4.3 Bit Parameter inDiFlags

This IO Configuration Parameter groups Bit Parameters which are represented by one bit only (e.g. having an "on" or "off" state).

Parameter	<i>inDiFlags</i>	Access	Read / Write
Address	0x1101		
Values	Bit Parameters		
	Bit Parameter	Bit Position	
	<i>inDiAddCounter</i>	Bit 0	
	<i>inDiResetCounterOnRead</i>	Bit 1	
	<i>inDiInverted</i>	Bit 2	
Default Value	0x00	Parameter Type	1 Byte unsigned

Tab. 19 IO Configuration Parameter *inDiFlags*

The parameter *inDiFlags* cannot be accessed directly by using the Command Line Tool. The Bit Parameters can be used instead.

If *inDiFlags* is changed by the SetParam command the update must be performed in a read-modify-write sequence in order to prevent overwriting other bit parameters.

3.4.3.1 *inDiInverted*

This Bit Parameter configures the input signal value inversion.

Parameter	<i>inDiFlags</i>	Access	Read / Write
Address	0x1101	Parameter bit <i>inDiFlags</i>	
Values	Bit Parameter	Bit Position	
	<i>inDiInverted</i>	Bit 2	
Default Value	Off	Parameter Type	1 Bit
LucidIoCtrl Command Line Tool			
Parameter Name	<i>inDiInverted</i>	Parameter Values	on / off
Call (Set)	LucidIoCtrl -d[COMx] -c[Channel] -sinDiInverted=[Value] {-p} {--default}		
Call (Get)	LucidIoCtrl -d[COMx] -c[Channel] -ginDiInverted		

Tab. 20 IO Configuration Parameter Bit *inDiInverted*

LucidIoCtrl Command Line Tool Example

Enable input signal value inversion of channel 0 and make the setting persistent.

```
LucidIoCtrl -dCOM4 -c0 -sinDiInverted=on -p
```

Read input signal value inversion flag of channel 0.

```
LucidIoCtrl -dCOM4 -c0 -ginDiInverted
```

```
-> inDiInverted=on
```

3.4.3.2 inDiAddCounter

This Bit Parameter controls how the counter value is updated after count interval time T_{Count} has finished. It is relevant in Count Mode only (→ 3.2.3).

Parameter	<i>inDiFlags</i>	Access	Read / Write
Address	0x1101	Parameter bit <i>inDiFlags</i>	
Values	Bit Parameter		Bit Position
	<i>inDiAddCounter</i>		Bit 0
Default Value	Off	Parameter Type	1 Bit
LucidIoCtrl Command Line Tool			
Parameter Name	<i>inDiAddCounter</i>	Parameter Values	on / off
Call (Set)	LucidIoCtrl -d[COMx] -c[Channel] -sinDiAddCounter=[Value] {-p} {--default}		
Call (Get)	LucidIoCtrl -d[COMx] -c[Channel] -ginDiAddCounter		

Tab. 21 IO Configuration Parameter Bit *inDiAddCounter*

LucidIoCtrl Command Line Tool Example

Enable counter add on update for input channel 0 and make the setting persistent.

```
LucidIoCtrl -dCOM4 -c0 -sinDiAddCounter=on -p
```

Read counter add setting of input channel 0

```
LucidIoCtrl -dCOM4 -c0 -ginDiAddCounter
-> inDiAddCounter=on
```

3.4.3.3 inDiResetCounterOnRead

This Bit Parameter controls how to update the counter value after it was read. It is relevant in Count Mode only (→ 3.2.3).

Parameter	<i>inDiFlags</i>	Access	Read / Write
Address	0x1101	Parameter bit <i>inDiFlags</i>	
Values	Bit Parameter		Bit Position
	<i>inDiResetCounterOnRead</i>		Bit 1
Default Value	Off	Parameter Type	1 Bit
LucidIoCtrl Command Line Tool			
Parameter Name	<i>inDiResetCounterOnRead</i>	Parameter Values	on / off
Call (Set)	LucidIoCtrl -d[COMx] -c[Channel] -sinDiResetCounterOnRead=[Value] {-p} {--default}		
Call (Get)	LucidIoCtrl -d[COMx] -c[Channel] -ginDiResetCounterOnRead		

Tab. 22 IO Configuration Parameter Bit *inDiResetCounterOnRead*

LucidIoCtrl Command Line Tool Example

Enable counter reset on read for input channel 0 and make the setting persistent.

```
LucidIoCtrl -dCOM4 -c0 -sinDiResetCounterOnRead=on -p
```

Read counter reset setting of input channel 0

```
LucidIoCtrl -dCOM4 -c0 -ginDiResetCounterOnRead
-> inDiResetCounterOnRead=on
```

3.4.4 inDiScanTime

This IO Configuration Parameter specifies the scan time T_{Scan} of the digital input.

Parameter	<i>inDiScanTime</i>	Access	Read / Write
Address	0x1111		
Values	T_{Scan} in μ s (micro seconds) $80 \mu\text{s} \leq T_{Scan} \leq 1 \text{ s}$		
Default Value	50,000 (50 ms)	Parameter Type	4 Bytes unsigned
LucidIoCtrl Command Line Tool			
Parameter Name	<i>inDiScanTime</i>	Parameter Values	Time [μ s]
Call (Set)	LucidIoCtrl -d[COMx] -c[Channel] -sinDiScanTime=[Time] {-p} {--default}		
Call (Get)	LucidIoCtrl -d[COMx] -c[Channel] -ginDiScanTime		

Tab. 23 IO Configuration Parameter *inDiScanTime*

LucidIoCtrl Command Line Tool Example

Set T_{Scan} of input channel 0 to 1.5 s and make the setting persistent.

```
LucidIoCtrl -dCOM4 -c0 -sinDiScanTime=1500000 -p
```

Read T_{Scan} parameter of input channel 0

```
LucidIoCtrl -dCOM4 -c0 -ginDiScanTime
-> inDiScanTime=1500000
```

3.4.5 inDiCountTime

This IO Configuration Parameter specifies the count time T_{Count} of the digital input in Count Mode (\rightarrow 3.2.3).

Parameter	<i>inDiCountTime</i>	Access	Read / Write
Address	0x1112		
Values	T_{Count} in μ s (micro seconds) $1 \text{ ms} \leq T_{Count} \leq 1 \text{ h}$		
Default Value	5,000,000 (5 s)	Parameter Type	4 Bytes unsigned
LucidIoCtrl Command Line Tool			
Parameter Name	<i>inDiCountTime</i>	Parameter Values	Time [μ s]
Call (Set)	LucidIoCtrl -d[COMx] -c[Channel] -sinDiCountTime=[Time] {-p} {--default}		
Call (Get)	LucidIoCtrl -d[COMx] -c[Channel] -ginDiCountTime		

Tab. 24 IO Configuration Parameter *inDiCountTime*

LucidIoCtrl Command Line Tool Example

Set T_{Count} of input channel 0 to 10 s and make the setting persistent.

```
LucidIoCtrl -dCOM4 -c0 -sinDiCountTime=10000000 -p
```

Read T_{Count} parameter of input channel 0

```
LucidIoCtrl -dCOM4 -c0 -ginDiCountTime  
->inDiCountTime=10000000
```

4 Specification

Parameter		Condition	Value
Inputs			
	No of Input Channels		16
Inputs - Electrical Characteristics			
Input Signal Maximum Low Level	5V	$U_{05MaxLow}$	
	10V	$U_{10MaxLow}$	
	24V	$U_{24MaxLow}$	
Input Signal Minimum High Level	5V	$U_{05MinHigh}$	
	10V	$U_{10MinHigh}$	
	24V	$U_{24MinHigh}$	
Input Signal Maximum Voltage ^{Note1}	5V	U_{5Max}	7.5 V
	10V	U_{10Max}	15 V
	24V	U_{24Max}	30 V
Input Impedance		R_{In}	> 1 k Ω
Outputs – Electrical Characteristics			
IO20 Output Voltage	$R_L = \infty$	U_p	4.7 - 5.5 V
	$R_L = 100 \Omega$		4.3 – 5.0 V
Max. IO20 Output Current		I_p	80 mA
Inputs – Timing Characteristic			
T_{Scan}		$t_{Min} < T_{Scan} < 1 s$	
T_{Count}		$t_{Min} < T_{Count} < 1 h$	
Minimum pulse length		t_{Min}	1 ms
Timer Resolution		t_{Res}	10 μs
Maximum Frequency of Input Signal in Count Mode		1000 Hz	
Module – Host Interface			
USB		2.0 Full Speed CDC Profile	
Power Supply		USB Power supplied	
Maximum Rated Supply Current		250 mA	
Module – Environment			
Temperature		Storage	-20 °C ... +70 °C
		Operation	0 °C ... +55 °C
Humidity		< 85 % RH, non-condensing	
Module – Housing			
Dimension L x W x H		90 x 54 x 62 mm	
Weight (in total)		120 g	
Assembly		Rail-Mount (EN 50022, TS35)	
Protection Class (DIN 40050)		IP20	

Tab. 25 DI16 Specification

Note1 Maximum forward and reverse voltage

Module is specified at environmental temperature of 25°C.

5 Order Information

Order Code	Product
LCTR-DI16-5	LucidControl Digital Input USB Module with 16 insulated Channels for 5 Volt Signals
LCTR-DI16-5-P	LucidControl Digital Input USB Module with 16 Channels for 5 Volt Signals and Voltage Output
LCTR-DI16-10	LucidControl Digital Input USB Module with 16 insulated Channels for 10 Volt Signals
LCTR-DI16-24	LucidControl Digital Input USB Module with 16 insulated Channels for 24 Volt Signals

Tab. 26 Digital Input Module Order Codes

6 Document Revision

Date	Rev.	
2024/11/07	1.0	Initial Version

Tab. 27 Document Revision



deciphe it GmbH
 Schäferstr. 5
 87600 Kaufbeuren / Germany
www.lucid-control.com